

Owners Manual

MAX-11 Slow Fire Upper Receiver



LAGE Manufacturing, L.L.C. 1792 E. Shannon St. Chandler Arizona 85225

CM11-300

NFA Warning

This upper receiver is designed to be used with the SWD M-11/9 submachine gun. NFA (National Firearms Act, Title 26, United States Code) rules apply to its use and possession.

It is the owners/users responsibility to comply with all local, State and Federal laws and regulations in the use of this product.

Description/Features

The MAX-11 Slow Fire Upper Receiver (SF) is designed to provide additional capability to the SWD M-11/9 submachinegun. Utilizing a bolt weight, the rate of fire is reduced to around 600 rounds per minute. This allows easy controllability of fire and the ability to consistently fire single and two round bursts from the automatic setting.

The MAX-11 SF attaches to the stock M-11/9 lower receiver without any modification to the lower receiver.

Features:

- 1) Rear Sight , Adjustable
- 2) Front Sight , Adjustable
- 3) Scope/Optics rail (Mil-Std-1913)
- 4) Front Hand Grip
- 5) Front Grip Retaining Pin
- 6) Lower Accessory Rail (Mil-Std-1913)
- 7) 8 inch barrel length, removeable (threaded 1/2-28)
- 8) Flash Suppressor
- 9) Side Accessory Rail Mounting Points
- 10) Cocking Handle (reciprocating)

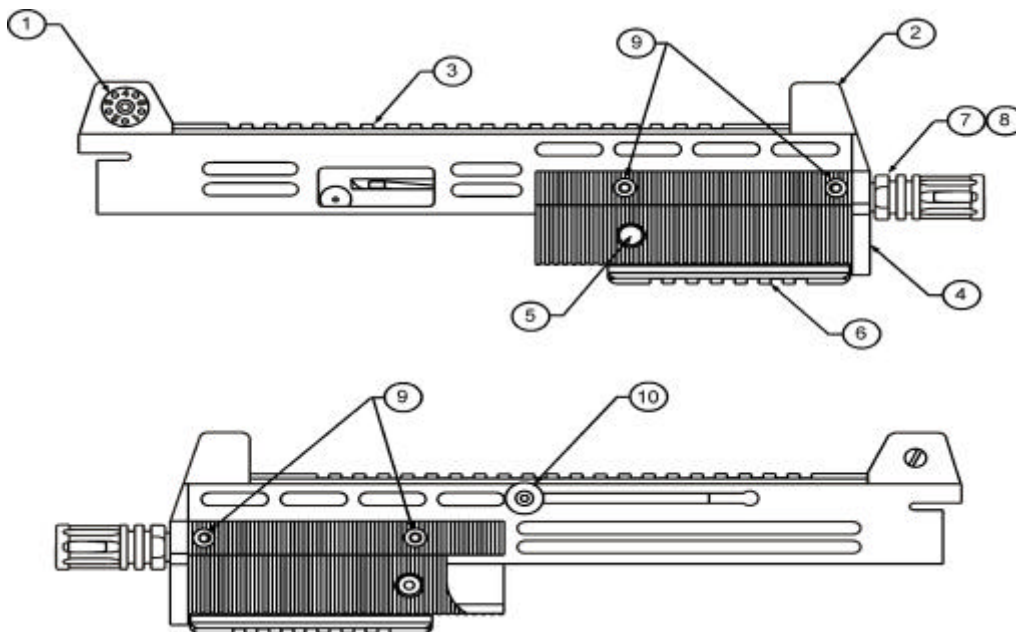

Installation

- ① Insure firearm is unloaded. Point in a safe direction. Remove magazine and pull bolt to the rear to insure chamber is empty.



- ② While holding cocking knob, pull trigger and ease bolt forward into closed position.



- ③ Remove front pushpin and detach upper receiver from lower receiver.



- ④ With front grip and retaining pin removed from MAX-11 Slowfire Upper Receiver, slide rear of upper receiver assembly into rear of lower receiver until receiver holes align.



- ⑤ Align front grip with grip sides on upper receiver.



- ⑥ Slide grip back and insure front of grip locks in under front sight and hole in grip sides align with receiver hole.



- ⑦ Push retaining pin through right side until fully seated.



Removal

- ① Point firearm in a safe direction and insure it is unloaded and magazine is removed.
- ② Using a bullet tip or pointed object, such as a pen tip, push on left side of retaining pin until it protrudes from right side.



- ③ Hold upper and lower receiver together with one hand and with other hand grasp protruding head of retaining pin and pull out.



- ④ Slide grip forward and away from upper receiver. Do not pivot grip downward when removing or you may risk breaking the front of the grip.



- ⑤ Remove upper receiver from lower receiver.



Operation

Cocking

Pull cocking knob to rear and release. Bolt will remain open.
Cocking knob will remain in rear position.



Sight Adjustment

One click equals 3/4" of elevation or windage at 50 yards or 1-1/2" at 100 yards. Rotating the front sight clockwise will raise the bullet impact point. Rotating the rear sight drum clockwise will move the bullet impact point to the left.



Upper Scope/Optics Rail

A full length rail for mounting a scope or other aiming device is located on the top of the upper receiver. The profile of the rail is a standard Mil-Std-1913 style and will accept Weaver or Mil-Std-1913 scope rings or mounting systems.



Lower Accessory Rail

A rail for attaching a front hand grip, laser aiming device, tactical flashlight or other device is attached to the bottom of the front handgrip.

Please note, some hand grips are not manufactured to the correct dimensions to mount on a Mil-Std-1913 rail. Insure the grip is correct before attaching. The recommended front grip is a TDI Model SVG.

Additionally, tactical flashlights designed for use with pistol accessory rails will fit on the accessory rail but will be a tighter fit.

The lower accessory rail may be removed to provide a slimmer grip. To remove, use an 1/8" allen key to remove the two screws that secure the rail to the grip. To re-install, use a drop of Loctite 242® on each screw and hand tighten. Do not over tighten the screws or you may shear the thread inserts from the polymer grip.



Side Accessory Rails (optional)

The MAX-11 SF can be fitted with left and right side accessory rails for mounting additional accessories. The optional accessory rails come with longer mounting screws. They are installed by removing the existing side grip mounting screws, placing the rails over the grip sides and installing the longer mounting screws. When installing the new screws, use Loctite 242® on the threads and be careful not to overtighten the screws.



Sling Attachment (optional)

A sling swivel can be attached to the upper receiver at either of the front grip side panel mounting points. The recommended swivel is the ACE Ltd. SS-AR. To install, remove a screw from the grip side and install the sling swivel kit per the manufacturers' instructions.

Additionally, if the optional side accessory rails are installed a sling mount can be installed directly to it. The recommended accessory rail sling mount is either the ACE Ltd. SM-R or ZM Weapons YHM-9485S. Install per the manufacturers' instructions.

The rear of the sling can be attached to the stock, if it is so equipped.



Attachment of Other Muzzle Devices

The barrel is threaded 1/2-28. The flash suppressor is torqued to 25 foot/pounds and secured with Loctite Threadlocker 242.

A lockwasher is intentionally not used in order to insure the mounting surface of the barrel remains square and burr free for optional use with a suppressor. If you choose to replace the flash suppressor with another type of muzzle device, insure it is designed for use with 9mm caliber bullets.

To prevent marring of the finish, apply masking tape to the flats on the barrel end and the flash suppressor. To remove the flash suppressor, attach a 3/4" open end wrench to the wrench flats on the barrel. Attach a second 3/4" open end wrench to the wrench flats on the flash suppressor. While holding the wrench attached to the barrel stationary, rotate the wrench attached to the flash suppressor counter-clockwise.



Attachment of a Sound Suppressor

A sound suppressor may be attached to the MAX-11SF by removing the flash suppressor. The threads on the MAX-11SF barrel are 1/2-28. A thread adapter can be used to couple suppressors with other thread sizes or mounting systems. Most commonly, a 1/2-28 to 3/4-10 thread adapter is required to use the suppressor that mates to the stock SWD M-11/9. When using the suppressor with the thread adapter, regularly tighten the suppressor to the thread adapter. It will have a tendency to loosen during firing. This is typical of the 3/4-10 mounting thread and is not related to the design of the MAX-11SF upper receiver.

The recommended supplier for thread adapters is TROS. Remove the flash suppressor per the above procedure and install the thread adapter per the manufacturers' instructions.

CAUTION: Due to the possible variance in the concentricity and squareness of the combined barrel, thread adapter and suppressor you will be using, it is recommended that thread adapters be installed by a qualified gunsmith and the mounted suppressor be inspected for alignment prior to firing. Additionally, some suppressor manufacturers' warranties expressly require that they thread the barrel for the firearm that their suppressor will be used on. The warranty for the MAX-11 Slowfire Upper Receiver applies only to the upper receiver assembly and not any accessories subsequently attached by the Customer.

Removal of Barrel

The barrel has been designed to allow easy removal and installation. There are 3/4" wrench flats at the muzzle end.

To prevent marring the finish of the upper receiver use a padded vise or hard wood inserts. Alternatively, apply a couple of layers of masking tape to the trunnion. Secure trunnion firmly in vise. Using a 3/4" open end wrench on the wrench flats at the muzzle end, turn the wrench counter clockwise to loosen and remove barrel. To re-install barrel, apply anti seize engine assembly lube to the barrel threads and insert barrel into trunnion. Hand thread barrel and tighten by turning the wrench clockwise. Use a torque wrench to tighten to 40 foot/pounds.



Cleaning, Lubrication and Maintenance

Cleaning and lubrication should be carried out per the original manual provided with the SWD M-11/9 with the following additional requirements:

Recommended cleaning interval is after each shooting session or 500 rounds of use.

Remove the upper receiver from the lower receiver. Slide the bolt assembly fully rearward. Remove the cocking knob from the left side of the receiver. Remove bolt assembly from upper receiver.

Clean upper receiver with solvent. The metal finish and polymer grips are resistant to most cleaning chemicals including Mineral Spirits, Acetone and MEK. Inspect all mounting screws for tightness.

Clean barrel using your preferred method.

Lightly coat all surfaces with gun oil. Wipe away any excess oil.

Clean the bolt assembly in solvent. Brush the bolt face and breach area with a nylon or brass brush to remove any built-up carbon deposits. Insure the bolt face is clean and free of debris.

Using a fingertip, apply a thin coat of gun oil to the bolt surfaces. Wipe away any excess oil. Add a drop of gun oil to the recoil spring where it meets the back of the bolt. Inspect the sear engagement surface for rounding or burrs. Small burrs may be removed with a file. If the surface is worn and preventing the sear from reliably engaging, discontinue use and have it repaired immediately.

Insert the bolt assembly into the upper receiver. Slide bolt assembly forward until hole in bolt assembly lines up with rear of slot in upper receiver. Install cocking knob and push bolt assembly forward. Re-install upper receiver and front hand grip to lower receiver.

Parts Replacement

The MAX-11 Slowfire Upper Receiver uses some parts that are common to the original SWD M-11/9. All replacement parts can be purchased from LAGE Manufacturing, L.L.C.. Additionally, you can purchase the following parts from any company that sells parts for the SWD M-11/9:

- Buffer
- Back Plate
- Recoil Rod
- Ejector Rod
- Extractor*
- Extractor Spring*
- Extractor Roll Pin*
- Recoil Spring **

* Removal and installation requires removal of the bolt weight from the bolt.

**The recoil spring is a modified stock SWD M-11/9 spring. 15 coils are removed to leave approximately 92 active coils.

The front and rear sight hardware are standard AR-15/M-16 components:

Rear Sight Parts:
Aperture
Flat Spring
Sight Drum
Roll Pin
Sight Screw
Detent Spring
Detent

Front Sight Parts:
Sight Post
Detent Spring
Detent

Referenced Manufacturers

Knights Armament Vertical Grip part number 98053
Knights Armament Co. / Knights Manufacturing Co. ,
7750 9th Street S.W., Vero Beach, Florida 32968

Loctite Threadlocker 242®

Loctite is a trademark of Loctite Corp, 1001 Trout Brook Crossing
Rocky Hill, CT 06067

Tdi Arms
www.tdi-arms.com

Z-M Weapons, High Performance Systems

203 South Street
Bernardston, Massachusetts 01337
www.zmweapons.com

TROS

PO Box 680
Clackamas, OR 97015
www.trosusa.com

ACE LTD. USA
PO BOX 191
Chicago Park, CA 95712
www.riflestocks.com

Warranty and Repair

WARRANTY

Note: Use of reloaded/remanufactured ammunition or steel or aluminum cased ammunition will void your warranty

The MAX-11 Slowfire Upper Receiver has been manufactured in a manner to insure it is defect free and durable. LAGE Manufacturing, L. L. C. warrants to the original purchaser that this product is free from defects in materials and workmanship for the period of One Year from the original date of purchase. This warranty does not apply to damage due directly or indirectly, to misuse, abuse, negligence or accidental, repairs or alterations outside our facilities or to lack of maintenance. We shall in no event be liable for death, injuries to persons or property or for incidental, contingent, special or consequential damages arising from the use of this product. The above limitation of exclusion may be subject to state law and may not apply to you.

To utilize this warranty, the MAX-11 Slowfire Upper Receiver must be returned to us packaged in a manner to preclude damage during transit and with shipping charges prepaid. Proof of purchase date, and a written description of the complaint must be included. If upon inspection, the complaint is verified, we will either repair or replace the product at our election or we may elect to refund the purchase price if we cannot readily and quickly provide a replacement. We will return the repaired product at our expense, but if we determine that there is no defect, or that the defect was a result of causes not within the scope of this warranty, then you must bear the cost of returning the product.

This warranty gives you specific legal rights and you may have other rights, which vary from state to state.